

RABBIT RD1545

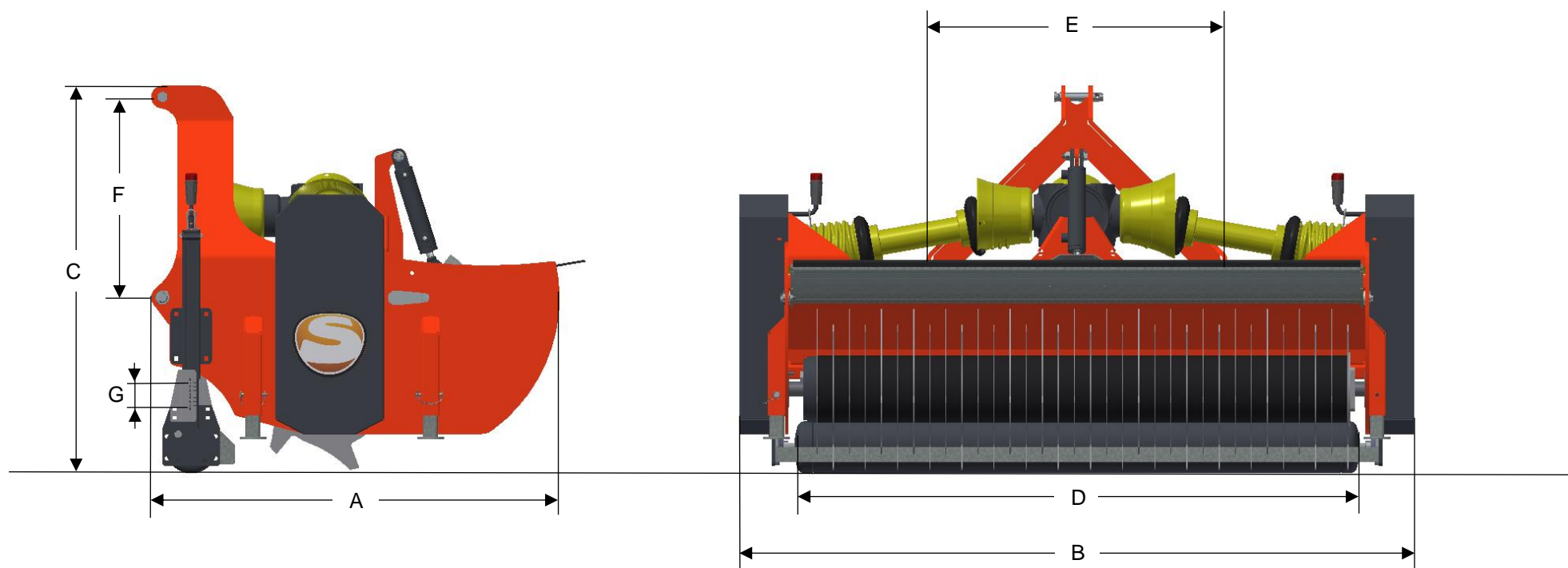

DIMENSIONS

A	LENGTH	1250 MM
B	WIDTH	1806 MM
C	HEIGHT	1020 MM
D	WORKING WIDTH	1500 MM

E	HITCH WIDTH	680-880 MM
F	DISTANCE LIFT PIN – LINK PIN	536 MM
G	ADJUSTMENT RANGE ROLLER	50 MM

RABBIT RD1545

MACHINE INFORMATION

TYPE	RD1545
WEIGHT	580 KG
HITCH TYPE	CAT 1 + 2
WORKING WIDTH	150 CM
MAX. WORKING DEPTH	50 MM
DRIVE	PTO – V-BELTS
PTO SPEED	1000 RPM
POWER REQUIREMENT	30 HP

TYPE OF SCARIFYING KNIVE	FIXED STAR-KNIVES
DIAMETER KNIVE	Ø 450 MM
NUMBER OF KNIVES	34 PIECES
DISTANCE BETWEEN KNIVES	40 MM
ROTATION SPEED KNIVE AXLE	1470 RPM
ROTATION DIRECTION KNIVE AXLE	CLIMB MILLING
ROLLER ADJUSTMENT	STEPLESS TO 50MM
DIAMETER ROLLER	Ø 140 MM
SLIDE ADJUSTMENT	HYDRAULIC