

IDEAL VTS140TA

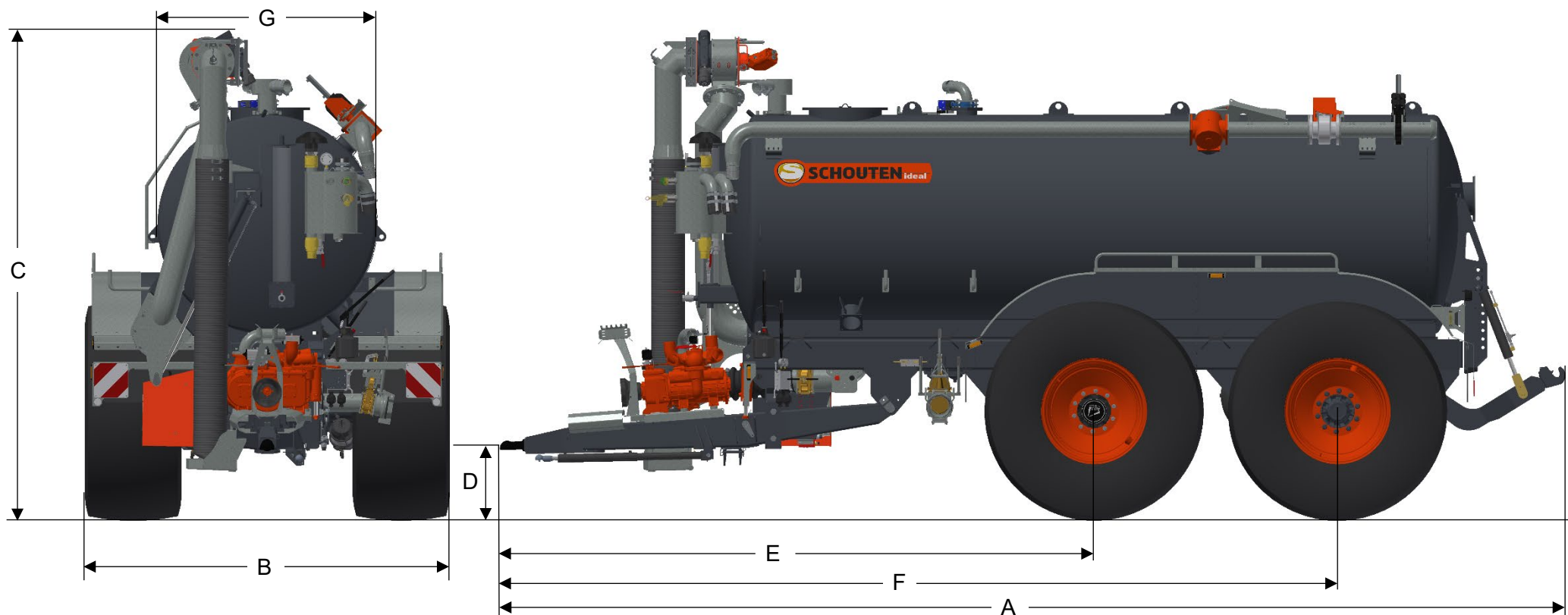

DIMENSIONS

A	LENGTH	8750 MM	E	DISTANCE HITCH – TANDEM	4880 MM
B	WIDTH	2950 MM	F	DISTANCE HITCH – TANDEM	6880 MM
C	HEIGHT	3940 MM	G	TANK DIAMETER	1800 MM
D	HITCH HEIGHT	400-600 MM	H	LIFT HEIGHT MIN. / MAX.	375-1115 MM

IDEAL VTS140TA

MACHINE INFORMATION

TYPE	VTS140TA
WEIGHT	11.780 KG
TANK DIMENSIONS	Ø 1800X5500 MM
TANK VOLUME	14.000 LTR
LEVEL INDICATOR	GAUGE/FLOAT POINTER
UNDERCARRIAGE	TANDEM-AXLE
TYPE OF TANDEM	BPW/ADR BRAKED
CARRYING CAPACITY TANDEM	30.000 KG
STANDARD TIRES	750/60R30.5

SUPPORT LEG	HYDR. DW
VACUUM PUMP	JUROP PNR155
CAPACITY VACUUM PUMP	15.200 L/MIN
VACUUM PUMP DRIVE	PTO 1000 RPM
MOISTURE TRAP CAPACITY	15.500 L/MIN
LIFT POSSIBILITIES	GRAS – BOUWLAND
LIFT CAPACITY	3.500 KG
LIFT SYSTEM	4-PUNTS CAT III

OPTIONS

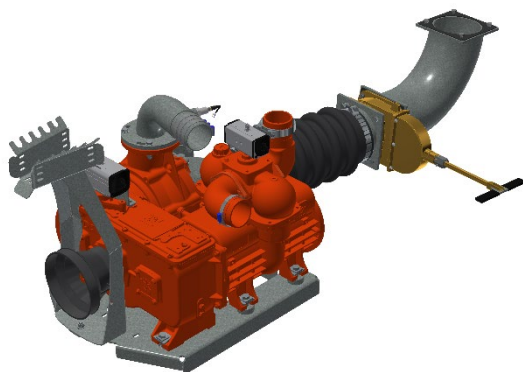

GARDA PUMPCOMBINATION

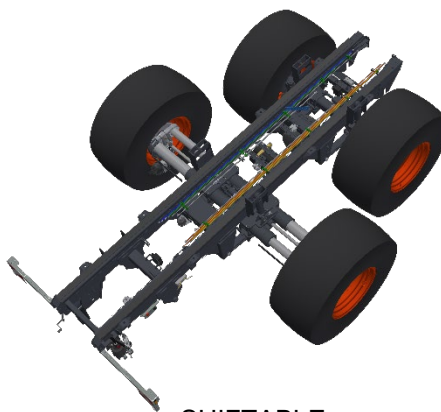

SHIFTABLE



FILLING ARM 8'' TURBO